

YAMAHA

OWNER'S/
OPERATOR'S
MANUAL

GOLF CAR

G2E

LIT-11626-06-56

J41-28199-14

©2019 Yamaha Golf-Car Company

©2019 Yamaha Golf Cart Company

G2-E

OWNER'S MANUAL

© 1988 by Yamaha Motor Co., Ltd.

1st Edition, March 1988

All rights reserved. Any reprinting or
unauthorized use without the written
permission of Yamaha Motor Co., Ltd.
is expressly prohibited.

Printed in Japan

LIT-11626-06-56

IMPORTANT:

PLEASE READ THIS MANUAL CAREFULLY AND COMPLETELY BEFORE OPERATING THIS VEHICLE.

Particularly important information is distinguished in this manual by the following notations.

NOTE: A NOTE provides key information to make procedures easier or clearer.

CAUTION:

A CAUTION indicates special procedures that must be followed to avoid damage to the machine.

WARNING:

A WARNING indicates special procedures that must be followed to avoid injury to a machine operator or person inspecting or repairing the machine.

WARNING:

To prevent possible injury, disconnect the battery before working on the vehicle. Remove the negative battery cable as shown below.

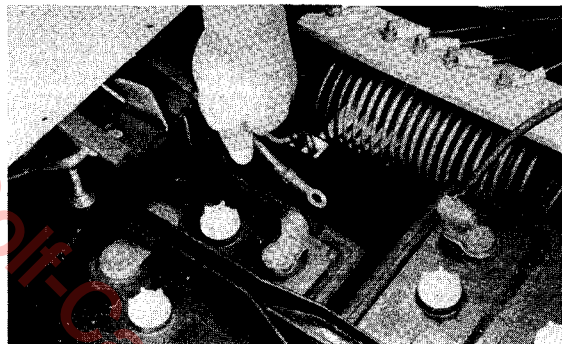
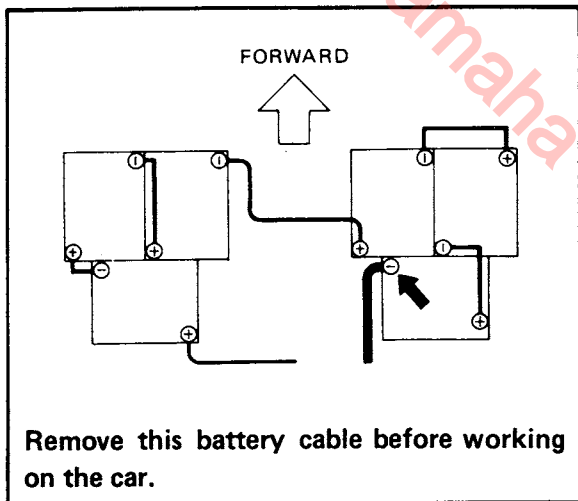

OPENING OF THE SEAT

1. Open the lid.
2. Pull up the lever and slowly open the seat forward.

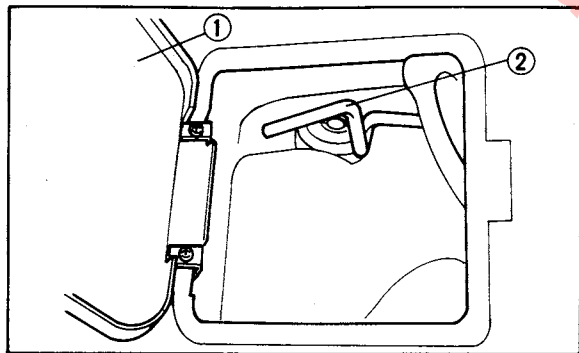

1. Lid

2. Lever

NOTE: _____

Depress the parking brake pedal when opening the body.

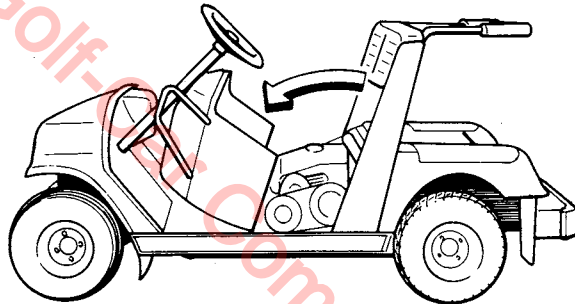

INTRODUCTION

Congratulations! Your choice of a Yamaha golf car assures you of the highest quality and dependability. Your Yamaha golf car is manufactured by a company well-known for excellence in the field of recreational vehicles, using the most advanced production equipment and technology. We are confident that this golf car will fully meet your needs. This manual is designed to acquaint you with the operation and minor maintenance required for satisfactory service of this golf car. Should major repairs ever be required, you are advised to consult your nearest Yamaha golf car dealer who will assure you of the best service. We hope that the information within this booklet will help you enjoy many hours of pleasure with your Yamaha golf car.

NOTICE: _____

Some data in this manual may become outdated due to improvements made to this model in the future. If there is any question concerning this manual, consult your nearby Yamaha dealer.

**SERVICE DEPT.
LEISURE VEHICLE AND POWER
PRODUCTS OPERATIONS
YAMAHA MOTOR CO., LTD.**

— MEMO —

©2019 Yamaha Golf-Car Company

CONTENTS

1. SAFETY WARNING.....	1	10. OWNER SERVICING.....	23
2. LOCATION OF THE "CAUTION AND SPECIFICA- TION LABELS".....	3	11. STORAGE AND RETURN TO SERVICE.....	45
3. DESCRIPTION.....	5	12. MAINTENANCE CHECK LIST.....	46
4. FEATURES.....	7	13. SPECIFICATION.....	57
5. MACHINE IDENTIFICATION.....	8	14. CIRCUIT DIAGRAM.....	58
6. MAIN PARTS FOR OPERATION.....	9	15. WARRANTY INFORMATION.....	59
7. OPERATION INSTRUCTIONS.....	11		
8. TIPS AND CAUTIONS.....	16		
9. PERIODIC MAINTENANCE AND MINOR REPAIR.....	17		



SAFETY WARNINGS

FAILURE TO OBEY THESE SAFETY WARNINGS MAY RESULT IN SEVERE PERSONAL INJURY OR DEATH.

BEFORE OPERATING THE VEHICLE

- Read the Owner's Manual carefully and understand the controls.
- Make pre-operation checks.
- Be sure all occupants are seated.
- Be sure the operator is authorized to operate the vehicle.
- Be sure the vehicle has no more than two persons aboard.
- Know where the designated driving areas are.
- Be sure the vehicle has not been modified; unwarranted modifications can render the car unsafe and could cause injury.
- Do not depress the accelerator pedal until the main switch has been turned on.

WHILE OPERATING THE VEHICLE

- Be sure all occupants remain seated and a passenger holds on to the arm rest.
- Keep arms, legs, and feet inside the vehicle.
- On an incline, drive up and down the incline in a vertical manner slowly — never at an angle.
- Slow down when turning.
- Avoid sharp, quick turns.
- Vary the speed of the vehicle to match the terrain.

- In reverse, drive slowly and watch where you are going.
- Do not exceed the factory speed setting of 12 mph under any circumstances.

BEFORE LEAVING THE VEHICLE

- Turn the key to the "OFF" position and remove it.
- Always set the parking break by firmly depressing the top of the brake pedal.
- Lock the wheels if parking on an incline; accidental movement of the accelerator pedal may cause the vehicle to roll down the incline.

1. LOCATION OF THE "CAUTION AND SPECIFICATION LABELS"

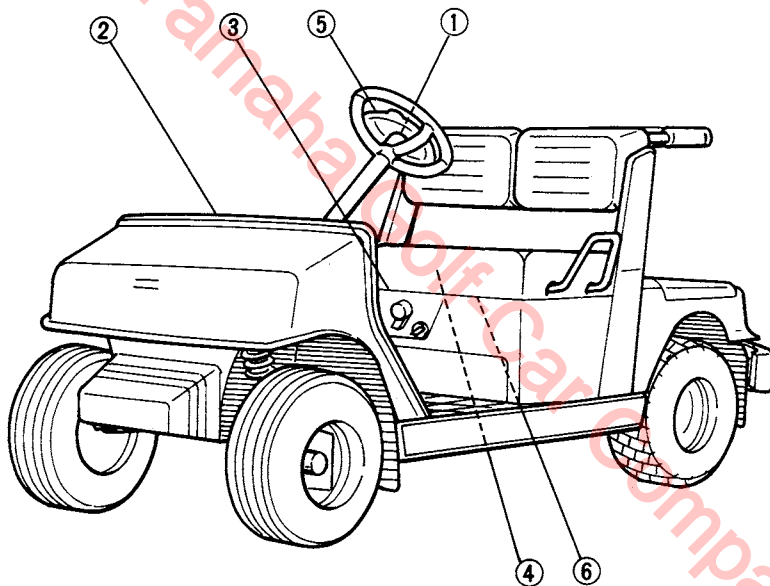

①

OPERATING INSTRUCTION

- BE SURE OCCUPANTS ARE SEATED SELECT FORWARD OR REVERSE SHIFT LEVER POSITION BEFORE TURNING IGNITION KEY ON.
- CAR STARTS AUTOMATICALLY WHEN ACCELERATOR PEDAL IS DEPRESSED. RELEASE THE PEDAL AND APPLY BRAKE TO STOP.
- ALWAYS SET THE PARKING BRAKE BY FIRMLY DEPRESSING THE TOP OF BRAKE PEDAL WHEN LEAVING CAR. BRAKE WILL AUTOMATICALLY RELEASE WHEN ACCELERATOR PEDAL IS DEPRESSED.
- BRING THE CAR TO A COMPLETE STOP BEFORE REVERSING DIRECTION.

WARNING

- OPERATE BY AUTHORIZED PERSONS ONLY AND ONLY IN DESIGNATED AREAS. NO CHILDREN ARE TO OPERATE.
- ONLY THE DRIVER AND ONE PASSENGER ARE ALLOWED.
- THIS VEHICLE WAS NOT MANUFACTURED FOR USE ON PUBLIC STREETS AND DOES NOT COMPLY WITH FEDERAL MOTOR VEHICLE SAFETY STANDARDS APPLICABLE TO PASSENGER CARS.

②

FOR YOUR SAFETY

- ALWAYS SET PARKING BRAKE BEFORE LEAVING CAR.
- DO NOT START THE CAR UNTIL ALL OCCUPANTS ARE SEATED.
- REMAIN SEATED WHEN THE CAR IS IN MOTION.
- DRIVE SLOWLY STRAIGHT UP AND DOWN SLOPES.
- AVOID SHARP, QUICK TURNS.
- KEEP ARMS, LEGS, AND FEET INSIDE THE CAR.
- ONLY THE DRIVER AND ONE PASSENGER ARE ALLOWED.
- OPERATE BY AUTHORIZED PERSONS ONLY AND ONLY IN DESIGNATED AREAS. CHILDREN ARE TO OPERATE.

③

CAUTION

DO NOT CHANGE SHIFT LEVER POSITION WHILE THE CAR IS MOVING.

④

WARNING

- BATTERY GASES ARE EXPLOSIVE.
 - KEEP SPARKS, FLAMES AND LIGHTED CIGARETTES AWAY FROM THE BATTERY.
- THE DANGER IS INCREASED WHILE CHARGING THE BATTERIES, WHEN THE BATTERIES ARE CHARGED IN THE VEHICLE, THE VEHICLE MUST BE IN A WELL VENTILATED AREA.

⑤

WARNING

DO NOT HOLD VEHICLE ON HILL/INCLINE WITH ACCELERATOR. THIS WILL DAMAGE MOTOR USE THE BRAKE.

(Battery)

⑥

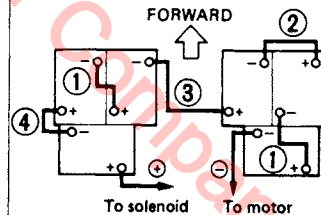
BATTERY INSTALLATION AND WIRE LEAD CONNECTION

2. DESCRIPTION

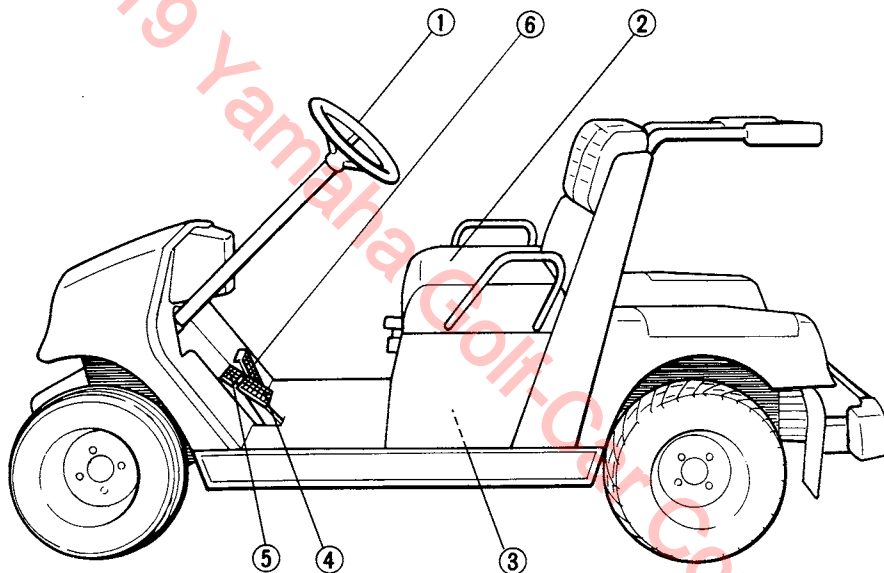

NOTE: _____

The golf car that you have purchased may differ partly in design and specifications from that shown in this photo.

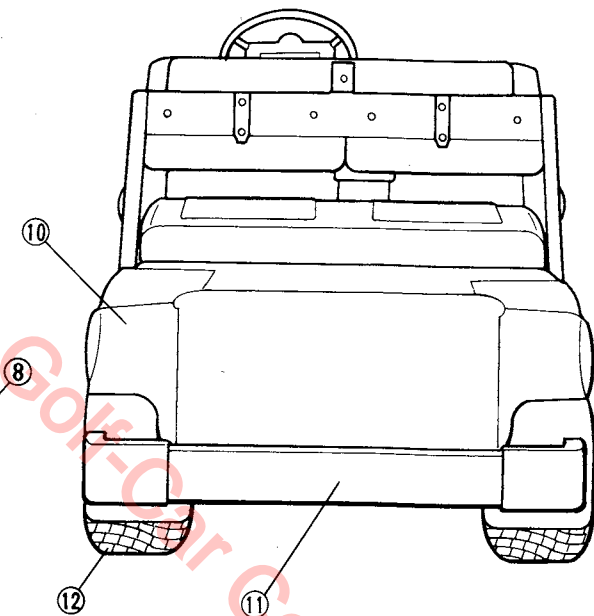
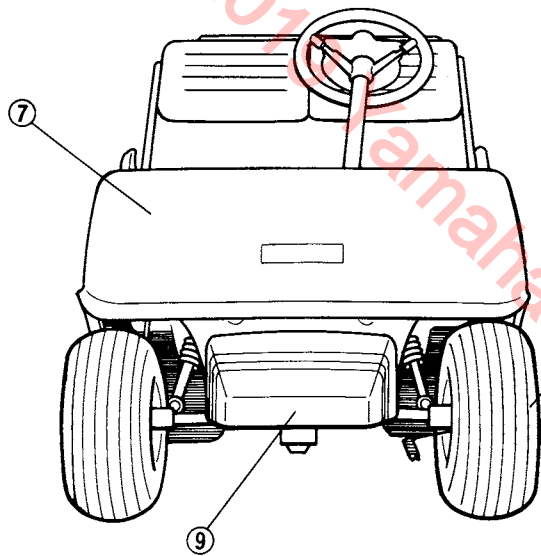

- 1. Steering wheel
- 2. Seat
- 3. Battery
- 4. Brake pedal

- 5. Parking brake pedal
- 6. Accelerator pedal
- 7. Front cowl
- 8. Front tire

- 9. Front bumper
- 10. Rear cowl
- 11. Rear bumper
- 12. Rear tire

3. FEATURES

1) Quietness

Yamaha has used every possible means to reduce the operating noise to the lowest possible level.

2) Acceleration

The 6-speed control switch allows smooth and powerful acceleration.

3) Riding comfort

Coil springs and shock absorbers provide suspension for both front and rear wheels for greatly improved comfort. This also improves steering and ensures stability.

4) Reliability

The reliability of Yamaha products is widely known among users. The direct drive mechanism simplifies the golf car's construction and increases its reliability.

5) Ease of service

The body shell is hinged to fully open to the rear, allowing easy access to the internal working components.

6) Durability

The front cowl is made of flexible urethane so that it can withstand a severe impact.

To increase the wear-resistance of the floor mat, it contains more fibers. All screws and floor metallic surfaces are specially treated for rust-resistance.

MACHINE IDENTIFICATION

Frame serial number

The frame serial number is located on the rectangular pipe under the operator's seat. The first three digits identify the model. This is followed by a dash. The remaining digits identify the production number of the unit.

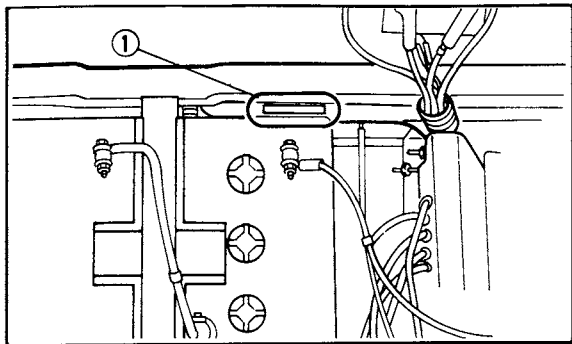

1. Frame serial number

5. MAIN PARTS FOR OPERATION

1) Main switch

Functions of the respective switch positions are as follows:

ON:

Electrical circuits are switched on. The key can not be removed in this position.

OFF:

Electrical circuits are switched off. The key can be removed in this position.

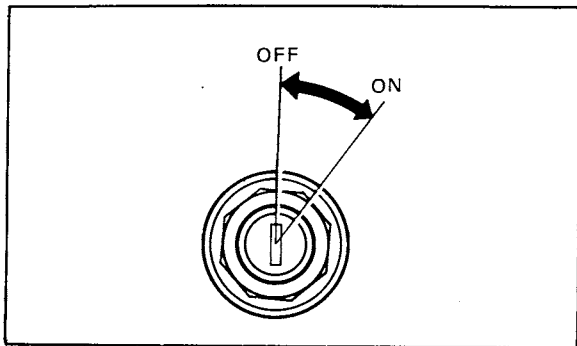

2) Drive select lever

Turn to the "F" for the forward position.
Turn to the "R" for the reverse position
and the back-up buzzer beeps of warning.

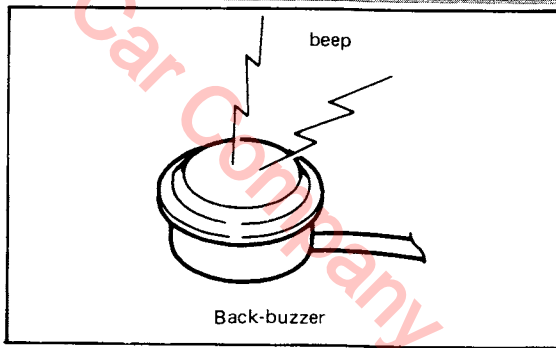
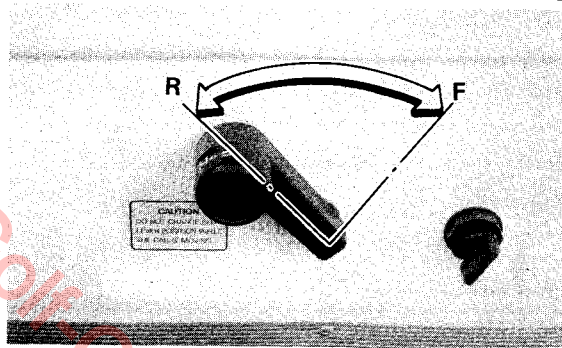

3) Accelerator pedal

With the drive select lever turn the "F" or "R" position, depressing the accelerator pedal will start the motor and make the car move in the selected direction. When the accelerator pedal is released, the motor will stop and the car will coast to a halt.

4) Brake pedal

When the brake is depressed, the brakes will be applied in proportion to the force applied to the brake pedal.

5) Parking brake

The parking brake – above the regular brake pedal – functions as a lock on the regular brake. By depressing both at the same time, the parking brake is actuated. Depressing the accelerator pedal automatically releases the parking brake.

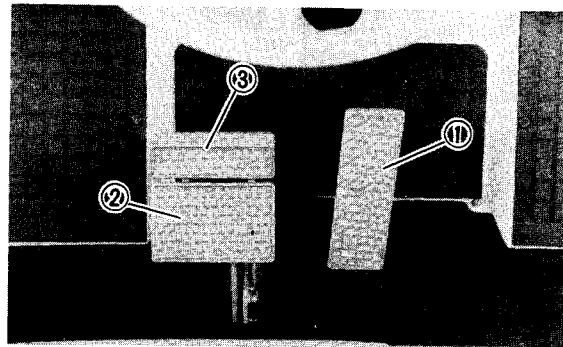

1. Accelerator pedal
2. Brake pedal
3. Parking brake

6. OPERATION INSTRUCTIONS

1) Driving

a. Forward

Turn the main switch to "ON".

Turn the drive select lever to "F".

Slowly depress the accelerator pedal. The car will start to move off. Do not depress the accelerator pedal too sharply.

WARNING:

- Do not depress the accelerator pedal before turning on the switch, or too sharply.
- Avoid starting or stopping abruptly; it's hard on the car and the turf.
- Avoid turning the steering wheel too sharply at high speed, an accident may result.

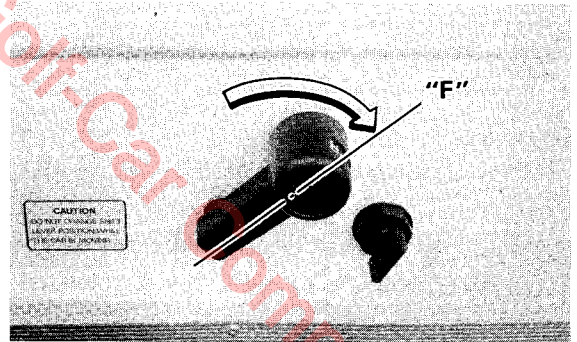
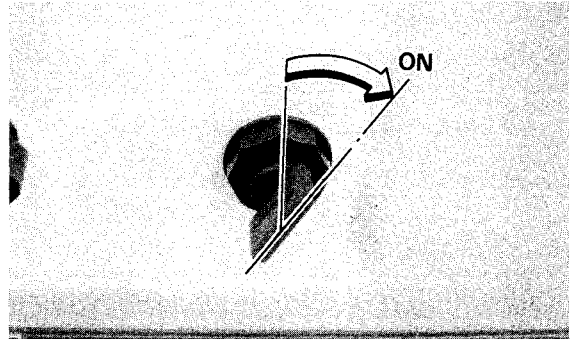

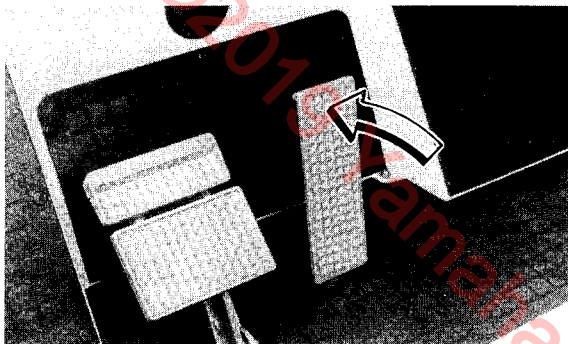

NOTE:

Total distance traveled per battery charge will be greater if full speed is utilized whenever safety and conditions permit. The most efficient mode of operation is when the accelerator pedal is fully depressed.

b. Reverse

Turn the main switch to "ON". Turn the drive select lever to "R". When the drive select lever is turned to "R", the back-up buzzer will sound. Slowly depress the accelerator pedal and the motor will start.

CAUTION:

Bring the car to a complete stop before changing directions.

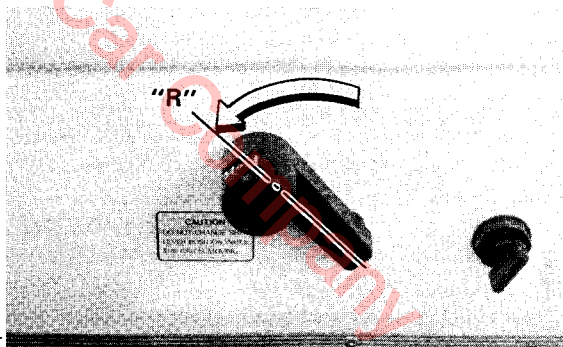
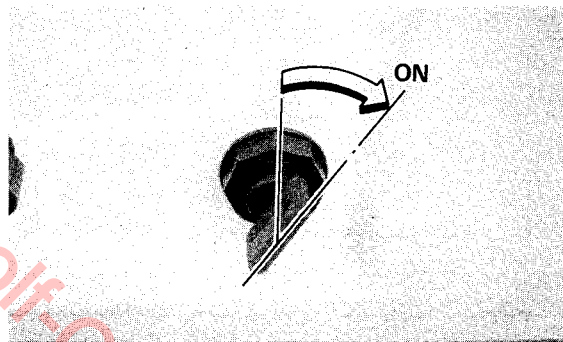

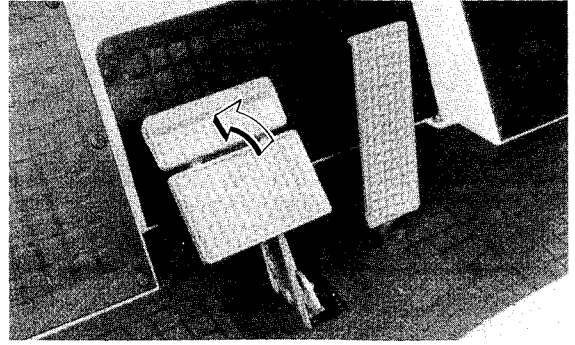
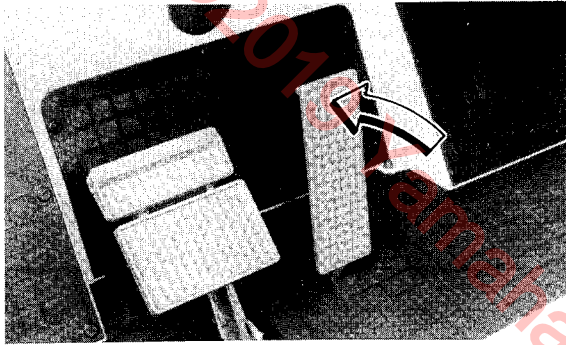

c. Starting on an upward slope

On an upward slope, set the parking brake, turn the main switch to "ON". Turn the drive select lever to "F" and depress the accelerator pedal.

WARNING:

Always drive straight up or straight down inclines; never at an angle.

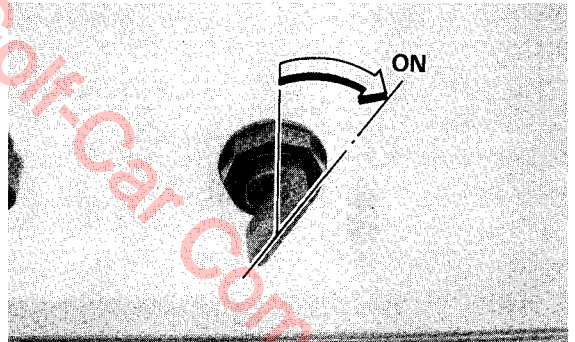

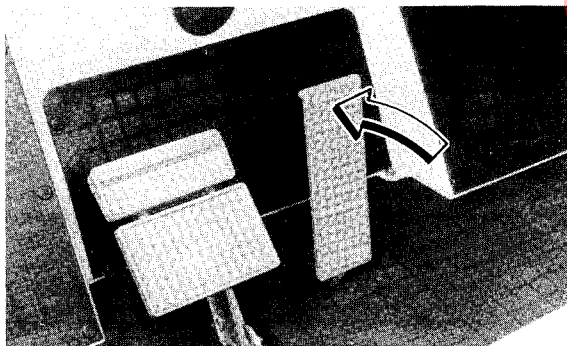
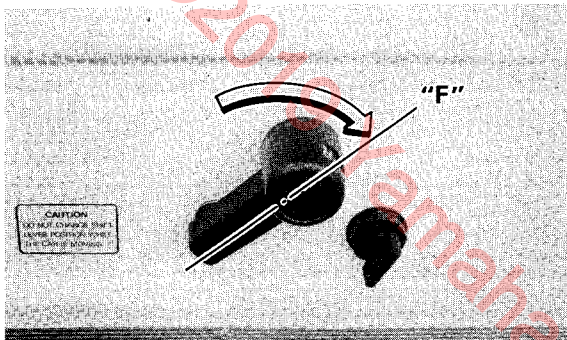

2) Stopping

To slow or stop the car, move your foot off the accelerator pedal and carefully depress the brake pedal as much as necessary.

3) Parking

a. Parking

Depress both the regular brake pedal and the parking brake pedal at the same time to actuate the parking brake.

WARNING:

- Park the car on a level surface as much as possible.
- Do not leave the car unattended unless main switch is in the "Off" position or key is removed, and the parking brake is on. Accidental movement of the accelerator pedal will put the car in motion or may cause it to coast down an incline.

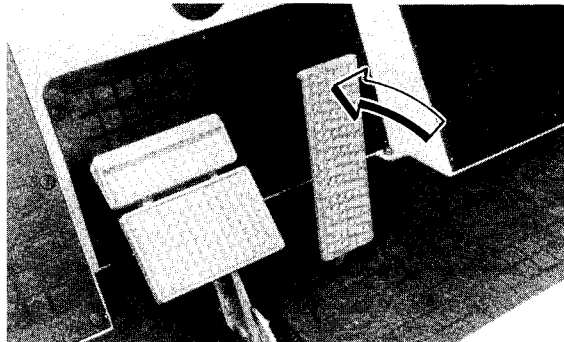
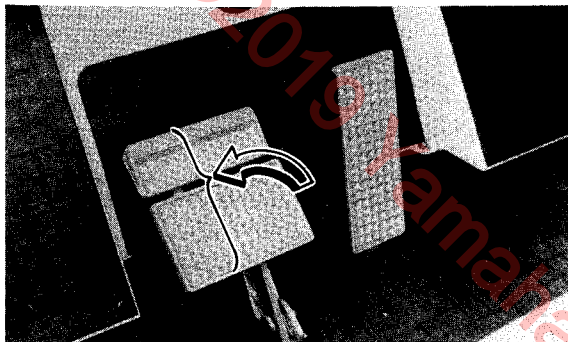

b. Unparking

Set the main switch to off. To release the parking brake, depress the accelerator slightly.

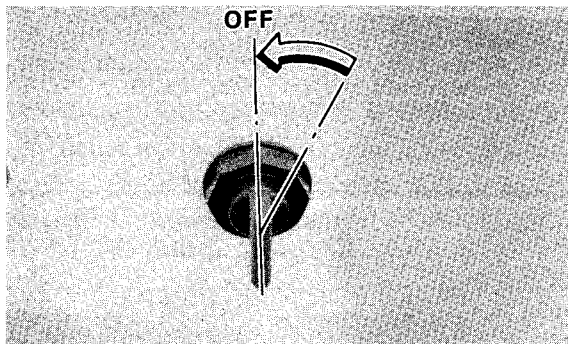

7. TIPS AND CAUTIONS

Driving the Yamaha golf car is very easy, even for beginners completely unfamiliar with golf car operation. However, special attention is required for safe operation when driving over varied terrain.

- * Bring the car to a complete stop before changing directions.
- * Do not depress the accelerator pedal too sharply.
- * Avoid starting or stopping abruptly; it's hard on the car and the turf.
- * Avoid turning the steering wheel to sharply.
- * Keep your hands on the steering wheel, and your eyes on the path ahead.
- * Always drive straight up or straight down inclines; never at an angle.
- * When backing up, do so slowly, and watch where you are going.
- * Park the car on a level surface as much as possible.
- * Do not leave car unattended unless the main switch is in the "Off" position and the parking brake is on. Accidental movement of the accelerator pedal will put the car in motion or may cause it to coast down an incline.
- * Never allow more than two people to ride in the car.
- * Total distance traveled per battery charge will be greater if full speed is utilized whenever safety and conditions permit. The most efficient mode of operation is when the accelerator pedal is fully depressed.

8. PERIODIC MAINTENANCE AND MINOR REPAIR

Periodic inspection and adjustment will keep your electric golf car in the safest and most efficient condition possible. Safety is an obligation of the electric golf car owner.

The most important points of inspection and adjustment are explained in the following.

1) Daily check

For best operation from a safety and maintenance standpoint, it is important that any car that is not functioning correctly be removed from use until it is properly repaired. The only practical way to satisfy both requirements is to ask that the owner or whoever is responsible for moving the cars from the storage area to the use area be aware of the proper "feel" of

the car on such critical areas as BRAKE OPERATION, ACCELERATOR OPERATION, STEERING MOVEMENT AND PLAY, and other operator controls. Any function that does not have the proper "feel" should be inspected more closely. The best way to insure that proper attention is given to these items is to impress upon the owner or the person who moves the cars that it is an important part of the service procedure, and if responsibly carried out, can improve safety and prevent customer dissatisfaction.

WARNING:

If the owner is not familiar with electric golf car service, this work should be done by a Yamaha dealer.

2) Periodic maintenance table

Use this table to determine maintenance by the number of rounds (hours) or the period whichever comes first.

Item	Remarks	Daily	Every			Page
			5 Rounds 3 hours (Week)	20 Rounds 10 hours (Month)	Others	
Batteries	Charge	○				29 ~ 32
	Check electrolyte level.		○			23
	Clean tops and terminals, check for corrosion.		○			24
	Check for loose or broken connections.			○		34
	Check the specific gravity of electrolyte.		○		40 Rounds 20 hours (2 months) (all cells)	24 ~ 26
Accelerator (including speed controller)	Check for free movement and return	○				50
	Check for loose or broken wires and connections.			○		35 ~ 36
	Check controller contacts.				125 Rounds 60 hours (6 months)	39 ~ 42

Item	Remarks	Daily	Every			Page
			5 Rounds 3 hours (Week)	20 Rounds 10 hours (Month)	Others	
	Adjustment: Contact allowance [1.0 ~ 2.0 mm (0.04 ~ 0.08 in)]				250 Rounds 130 hours (year)	39 ~ 42
Resistor	Check for loose or broken wires and connections.			○		35 ~ 36
Solenoid relay	Check "click" (Solenoid contact sound).	○				50
	Check wires and connections.			○		35 ~ 36
Solenoid relay	Check solenoid contacts.				125 Rounds 60 hours (6 months)	35 ~ 36
Traction motor	Check for loose or broken connections.			○		—
	Check brush and commutator				1000Rounds 500 hours (4 years)	—
Wiring	Check all wire insulation for cracks and/or worn spots.				125 Rounds 60 hours (6 months)	—
Differential	Check gearbox oil level and leakage.				125 Rounds 60 hours (6 months)	43 ~ 44

Item	Remarks	Daily	Every			Page
			5 Rounds 3 hours (Week)	20 Rounds 10 hours (Month)	Others	
	Replace gearbox oil. Oil capacity: 800 cm ³ (0.70 Imp qt, 0.85 US qt) Oil type: SAE 90 gear oil				500 Rounds 250 hours (2 years)	43 ~ 44
Brakes	Check operation and adjust if necessary.	○				50
	Adjustment: Brake wire end play [0.1 ~ 0.5 mm (0.004 ~ 0.02 in)]				250 Rounds 130 hours (year)	37 ~ 38
	Check for wear or damage parking brake ratchet and stopper.				125 Rounds 60 hours (6 months)	49
	Check shoe lining thickness. Wear limit: 1.0 mm (0.04 in)				125 Rounds 60 hours (6 months)	—
Steering	Check operation and adjust if necessary.	○				49
	Check gearbox for grease leakage, Grease amount: 90 cc (3.17 Imp oz, 3.04 US oz) Grease type: Multi type grease				1000Rounds 500 hours (4 years)	—

Item	Remarks	Daily	Every			Page
			5 Rounds 3 hours (Week)	20 Rounds 10 hours (Month)	Others	
	Adjustment: Wheel alignment [Toe-in: Unloaded 10 ~ 20 mm (0.4 ~ 0.8 in), Fully loaded 0m (0 in)]				250 Rounds 130 hours (year)	—
	Check kingpin play.				250 Rounds 130 hours (year)	—
Wheel	Check tire pressure and correct if necessary. Front and rear: 98 kPa (1 kg/cm ² , 14 psi)	○				36, 51
	Check tire groove depth or for damage. Wear limit: 1.0 mm (0.04 in)				250 Rounds 130 hours (year)	36
	Check for play front wheel bearing.				250 Rounds 130 hours (year)	—
	Check for play rear axle bearing.				250 Rounds 130 hours (year)	—

Item	Remarks	Daily	Every			Page
			5 Rounds 3 hours (Week)	20 Rounds 10 hours (Month)	Others	
Body & Chassis	Check body and chassis for damage.				250 Rounds 130 hours (year)	—
	Check tightness of all bolts, nuts and screws.				250 Rounds 130 hours (year)	—
	Check shock absorber for oil leakage.				250 Rounds 130 hours (year)	—

NOTE:

Keep from high pressure water all the electric parts; solenoids, motor, resistor, and controller.

9. OWNER SERVICING

WARNING:

For any adjustments or repairs not mentioned in the preceding owner service section, take your golf car to the nearest Yamaha golf car service dealer.

1) Battery

The batteries can be easily maintained simply by opening the seat.

BATTERY CARE

To keep your batteries in top condition, follow this maintenance program on a regular basis:

- a. Check the electrolyte level daily. Fill to manufacturer's recommended level when necessary. Use only distilled water or other water certified within impurity limits for battery use. Do not overfill!

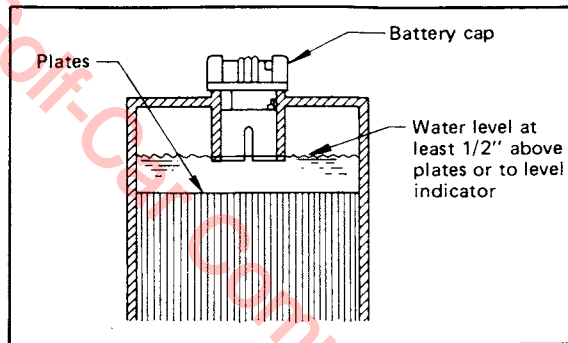
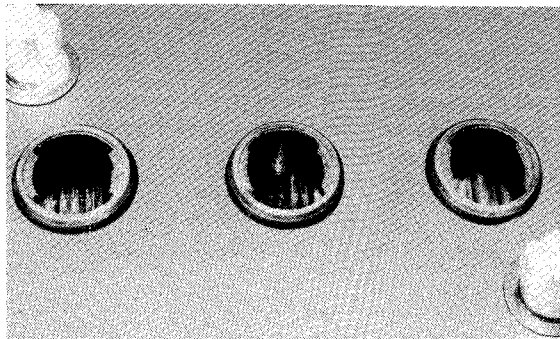



b. Clean the battery tops weekly by hosing off with a water hose. While this is being done, inspect the battery terminals, hold-downs and general area for corrosion. If found, consult your Yamaha dealer for corrective measures.

c. Check the specific gravity of the battery electrolyte every week by "spot checking" 3 ~ 4 cells.

Always first add water as necessary, then charge the batteries, then wait for the bubbles in the electrolyte to dissipate, then check specific gravity. Every two months, check all cells. If any low readings are found, consult your Yamaha dealer with this information to determine the appropriate action.

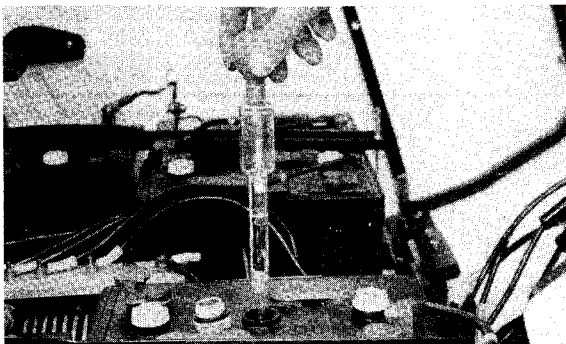

WARNING:

Battery electrolyte is poisonous and dangerous, causing severe burns, etc. If contains sulfuric acid. Avoid contact with skin, eyes or clothing.

Antidote: **EXTERNAL** – Flush with water. **INTERNAL** – Drink large quantities of water or milk. Follow with milk of magnesia, beaten egg or vegetable oil. Call physician immediately.

Eyes: Flush with water for 15 minutes and get prompt medical attention. Batteries produce explosive gases. Keep sparks, flame, cigarettes, etc., away. Ventilate when charging or using in enclosed space. Always shield eyes when working near batteries.

KEEP OUT OF REACH OF CHILDREN.

d. Specific gravity table

The specific gravity of battery electrolyte varies greatly according to temperatures; use the chart as reference.

Temperature		Satisfactory uncorrected hydrometer reading
°F	°C	
120	48.9	1.244
110	43.3	1.248
100	37.8	1.252
90	32.2	1.256
80	26.7	1.260
70	21.1	1.264
60	15.6	1.268
50	10.0	1.272
40	4.4	1.276
30	-1.1	1.280

The reading should be 1.260 at 80°F (26.7°C). If the specific gravity is low, charge the batteries. Before charging batteries, remove the vent caps, and be sure the vent holes are free to permit escape of gases. Then replace the vent caps on the batteries, and charge the batteries.

e. Hydrometer

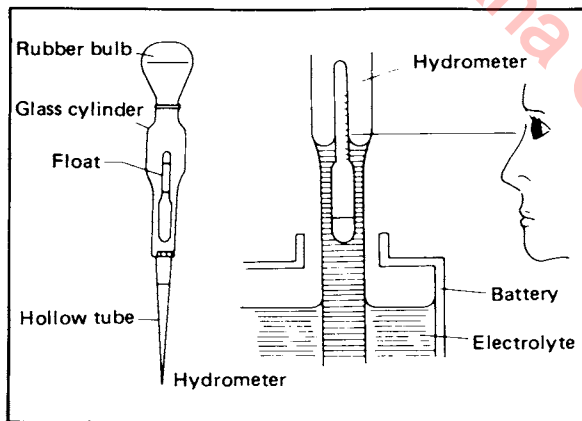

By squeezing and releasing the rubber bulb, fill with fluid until the float is positioned as in the illustration.

With the hydrometer float supported by the fluid, check the specific gravity. Be sure to read as illustrated.

BATTERY CARE FOR ELECTRIC CARS

WARNING:

Batteries emit hydrogen gas while they are charging. Hydrogen gas is extremely explosive. All possible sources of ignition, such as flames, sparks, etc., must be kept away from charging batteries.

1. New batteries must be given at least a 12-hour charge before their first use. Check the specific gravity to ensure adequate charging.
2. For the first five rounds, new batteries should go only 18 holes between charges.
3. Charge the batteries daily if they are used; the charge time is dependent on the amount the car is operated. In addition, a 30-minute charge between rounds helps extend battery life.
4. Add only distilled water to obtain the proper electrolyte level; do not overfill the cells. Never add electrolyte to a battery already in service.
5. Organize and store the cars so they get equal use.
6. Check the specific gravity of the electrolyte and refer to the catch-up chart to determine if a catch-up charge is needed.
7. The specific-gravity charts must be used to ensure proper charging; the charts should be prominently displayed.
8. Temperature has an effect on specific-gravity readings; this effect is computed on the specific-gravity charts. Use a combined hydrometer/thermometer for accurate readings. Never use a "floating ball" type hydrometer.
9. To ensure accuracy, hydrometers must be cleaned regularly; flush them with clean water after each day's use.

10. As batteries get older, their lives can be extended by decreasing the charge time from the normal 12 hours to as little as six hours when they are close to replacement.
11. Be sure the main switch of the car is turned off before charging the batteries.
12. The charger switch must be turned off when inserting and removing the charger plug at the car's receptacle; this will help prevent dangerous sparks near the batteries.
13. Place the charger cord carefully to avoid damage and accidents.
14. The charger should be mounted on a platform above the ground or in such a way to allow airflow beneath and around the charger; this will prevent overheating and possible damage to the charger.
15. Before charging batteries, remove the vent caps and inspect the vents for obstructions. Replace the vent caps after ensuring that the vents are clear, and proceed with charging.
16. Batteries which are operated with a low charge will soon sulfate, decreasing their service lives.
17. Overcharging batteries will seriously decrease their lives.

BATTERY CHARGING

NOTE:

Charge the batteries after each day of use, or periodically during extended storage.

- a. Turn the main switch to the "OFF" position.

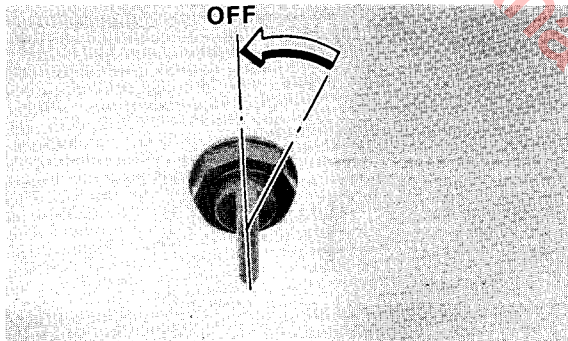

- b. Turn off the charger timer switch to the "0 Hr" position.

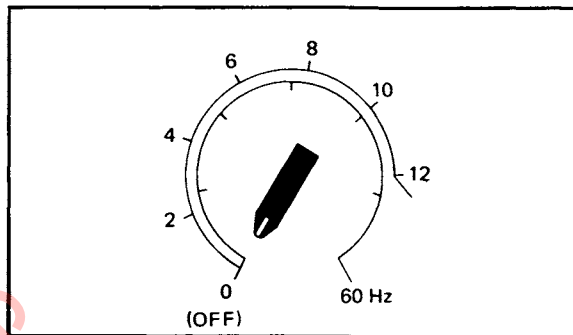

- c. Connect the AC plug of the battery charger to a wall socket.

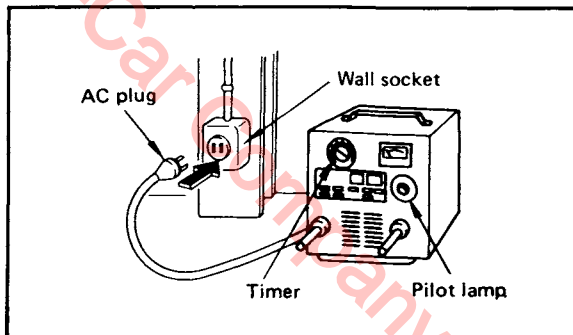

d. Open the lid.

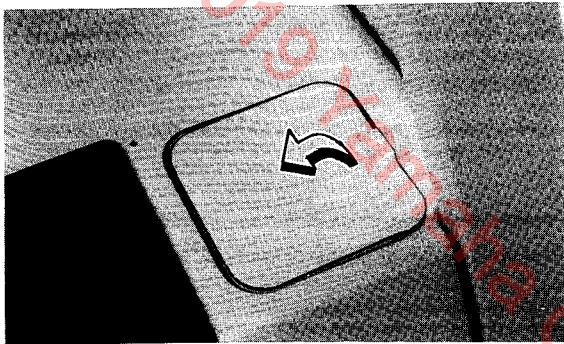

e. Open the receptacle cap.

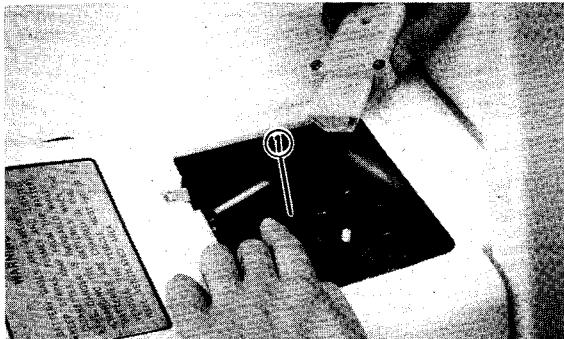

1. Receptacle cap

f. Insert the charger plug into the car's charging receptacle.

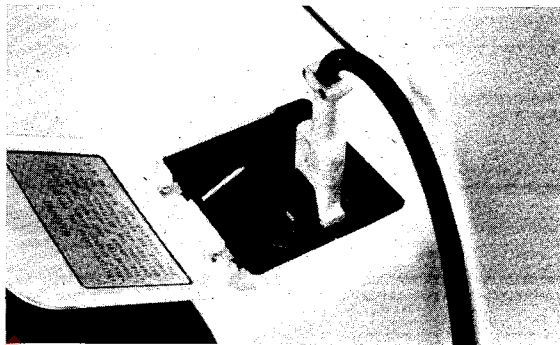

WARNING:

Do not unplug the charge from the receptacle in the car until the charger is turned off. Unplugging an operating charger will cause sparks.

- g. Set the timer to the desired charging time.
The charger will turn on for the indicated number of hours.

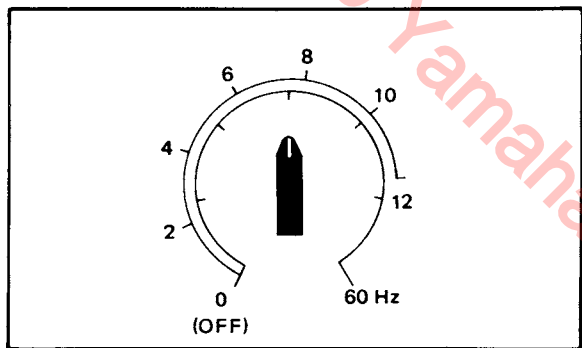

- h. When charging is complete, the switch turns off automatically.
i. Average charge durations are indicated in the chart below.

Golf car Use	Charging Time
9 holes or less	7 hours
18 holes or more	12 hours or more
Commercial Use	
Less than 1 hour	7 hours
More than 1 hour	12 hours or more

If use is greater than one round, charging between rounds is recommended. The best duration for a charge between rounds is a full recharge. If this is not possible, at least 30 minutes is recommended. If use was greater than 18 holes, and the finish rate is greater than 4 amps, additional recharging may be necessary. (See catch-up charging recommendations.)

If the specific gravity is less than 1.260 (corrected) charge the batteries according to the catch-up charge recommendations below.

If the specific gravity does not increase after the recommended time, the batteries are aging, and should be charged according to the finish rate chart.

Finish rate on Charger Ammeter	Timer setting
1 · 4 Amps	12 Hrs
6 · 8 Amps	10 Hrs
10 · 12 Amps	8 Hrs
15 Amps +	6 Hrs

NOTE:

Ambient temperatures of 38°C (100°F) or higher will cause high finish rates, use caution not to overcharge the batteries at these temperatures. Colder temperatures will require longer charging times.

Batteries should be charged every day that they are used even if the car only went 9 holes. However, the batteries should not be charged if they are not used unless testing

shows that a catch-up charge is required. This would lead to overcharging.

Catch-up and storage charge recommendations*:

State of charge (Specific Gravity)	Charge
1.260 to 1.280	None needed
1.240 to 1.260	4 Hours
1.220 to 1.240	8 Hours
Below 1.220	12 Hours

CAUTION:

- Take care that the batteries are not overcharged. This will shorten their life.
- Never charge the batteries in a closed area. Choose a well-ventilated area.

WARNING:

Keep fire and sparks away from the batteries while they are being charged. (Explosive gases are formed during charging)

BATTERY INSTALLATION AND WIRE LEAD CONNECTION

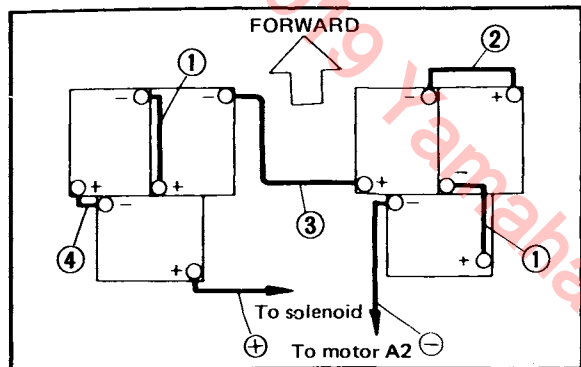

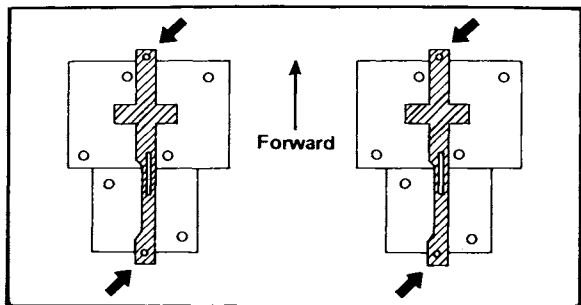

a. Install the battery holddown plates as shown.



CAUTION:

Do not overtighten the battery holddown nuts. Excessive force will damage the battery casing.

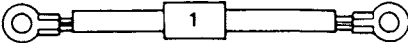
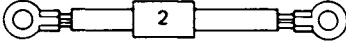
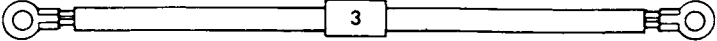
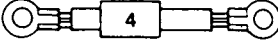
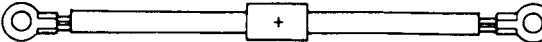
b. Connect the wire leads as shown. Each wire lead has its own length, position and identification mark.

No.	Items	Q'ty	Identification mark
1	Wire, lead 1	2	
2	Wire, lead 2	1	
3	Wire, lead 3	1	
4	Wire, lead 4	1	
	(Wire, positive lead)	1	 to Solenoid
	(Wire, negative lead)	1	 to motor A2

c. Keep all battery wires, connectors, and posts free of corrosion, and keep their connector bolts tight.

Corrosion should be prevented by use of chemically treated felt washers, special corrosion resistant spray coating, or grease.

d. Keep the batteries secured in position to avoid damage to the casing, internal parts, or connection posts and wires.

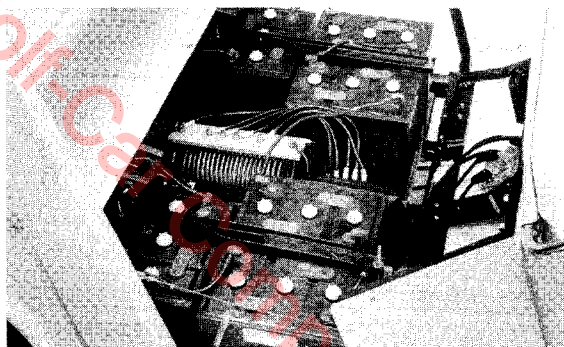

CAUTION:

- When installing batteries, be sure that maximum possible space is allowed between them to allow proper battery cooling.
- When placing batteries in the car, make sure there are no pebbles or any other things under the battery, and firmly secure them to the car.
- Never hammer the battery terminals when connecting the cable terminals to batteries.

WARNING:

When installing batteries or tightening electrical connectors or terminals, be careful to avoid short circuiting by:

- 1) Careful placement of battery cables and holddowns.
- 2) Avoid touching wrenches to ground when tightening terminal nuts (insulate wrench with tape).

- 3) Always remove the negative (–) cable to the traction motor first, and install it last.

WIRING

Keep the wiring secured in position to avoid damage to the casing, internal parts, or connection posts and wires.





2) Tires

Check the tire pressure. Tire pressure should be 0.9 kg/cm² (13 psi) for both front and rear tires. Check for wear or damage to the tires and replace any tire that is damaged or exceeds wear limit.

Minimum tread depth: 1 mm (0.04 in)

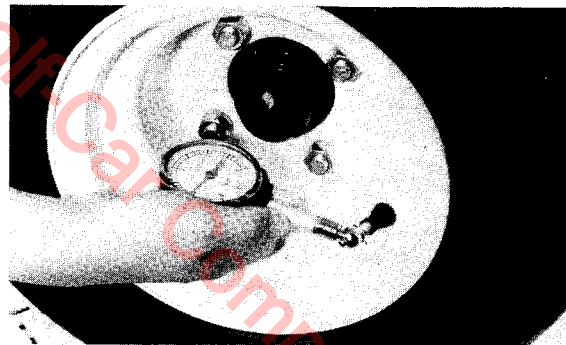
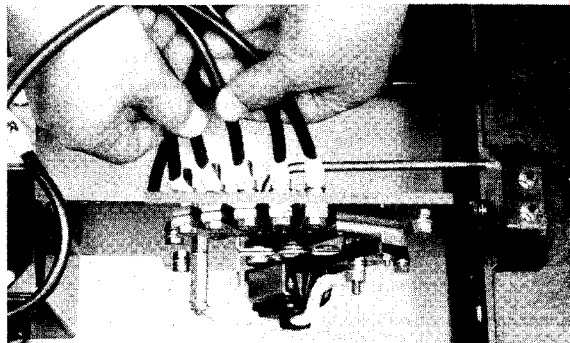

3) Brakes

PROCEDURE:

a. Brake shoe adjustment:

Brake shoes are self-adjusting. Before the initial start on a new car, just step down the brake pedal about 10 times to make sure that braking works.

b. Linkage adjustment:

- 1) Remove the floor panel, which is located to the rear of the brake pedal.

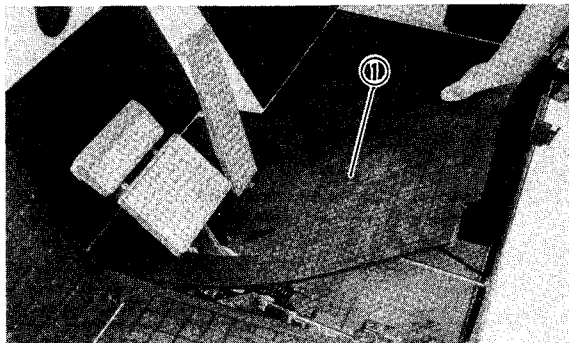

1. Floor panel

- 2) Check the brake wire end play as illustrated.

Brake wire end play:

0.1 ~ 0.5 mm (0.004 ~ 0.02 in)

WARNING:

1. To provide the brake shoe self-adjusting lever with an effective stroke, the brake wire end (as illustrated below) must be set just tight enough not to be loose [0.1 ~ 0.5 mm (0.004 ~ 0.020 in) play]. If the brake wire end play is too tight, it will not enable the self-adjusting device to work, thereby causing the brake pedal play (a) to increase with the resultant braking feel.
2. If the brake wire end play is too loose, it will cause the brake pedal play (a) to increase accordingly, also resulting in a bad braking feel.

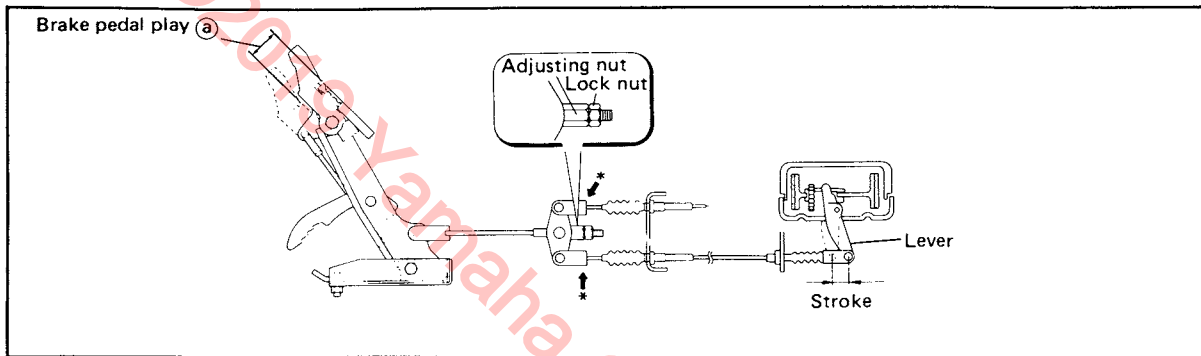

If necessary, adjust the brake wire end play by turning the adjusting nut and lock it with the Lock nut.

Adjustment (Adjusting nut)	Free play (Brake wire end)
Tightening	Decreasing
Loosening	Increasing

If this adjustment does not give smooth, even stopping without heavy pedal pressure, contact your Yamaha dealer before using your golf car again.

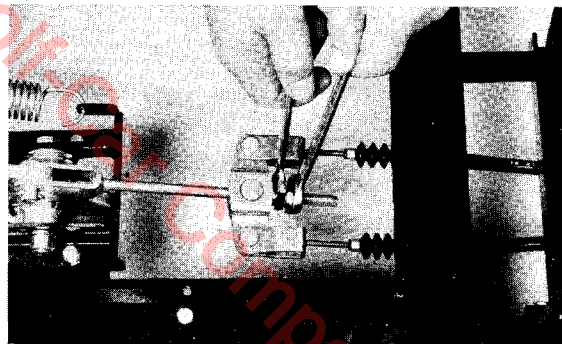

4) Adjustment of speed controller

- a. When the accelerator pedal is slowly depressed to the full extent, check whether moving contact is located in the position (A) (with the following allowance (B)) in relation to the fixed contact #6 see figure.

Allowance (B):

1 ~ 2 mm (0.04 ~ 0.08 in)

If not, loosen the two lock nuts (5) on the accelerator rod (6) and bring the movable contact to the correct position. Tighten the two lock nuts securely.

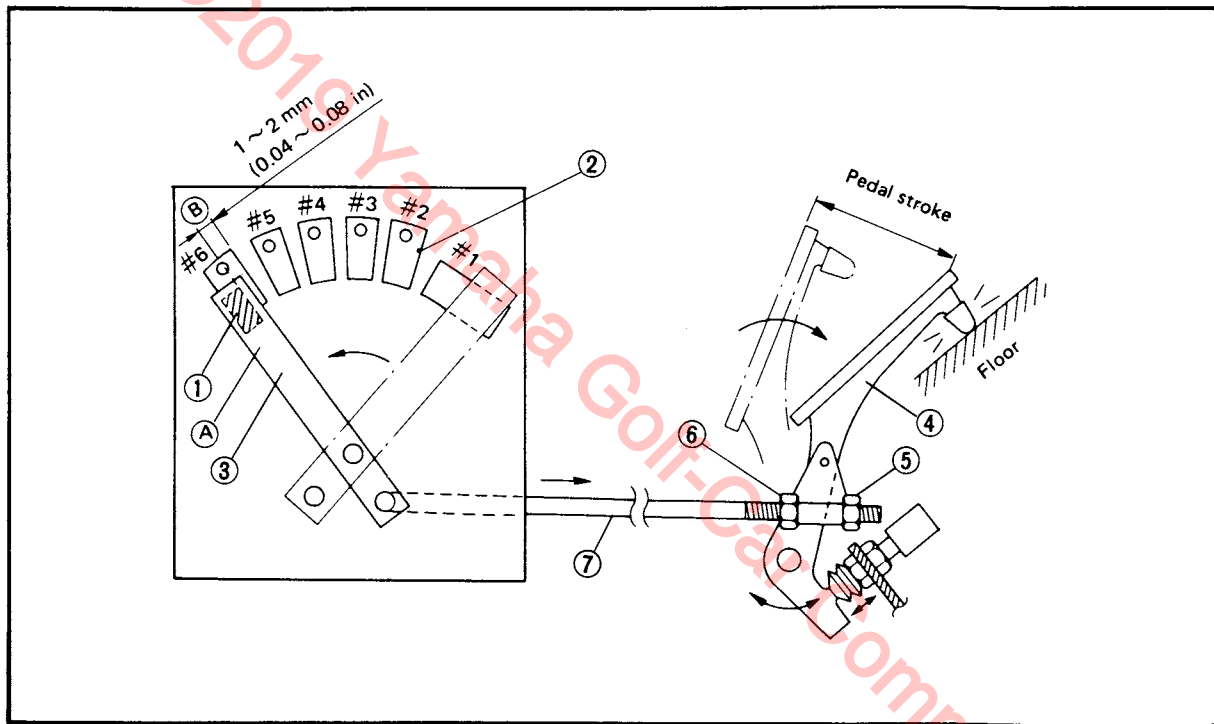

1. Moving contact
2. Fixed contacts (#1 ~ #6)
3. Moving arm

4. Accelerator pedal
5. Adjusting nut
6. Lock nuts

7. Accelerator rod

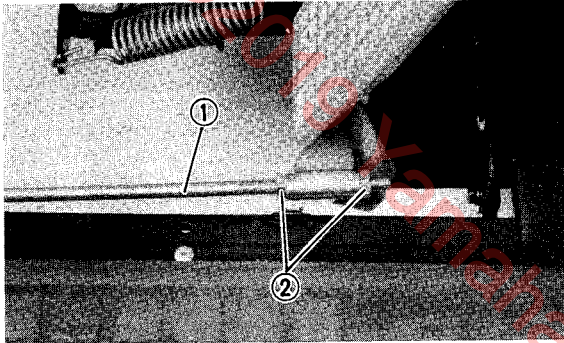

1. Accelerator rod
2. Lock nuts

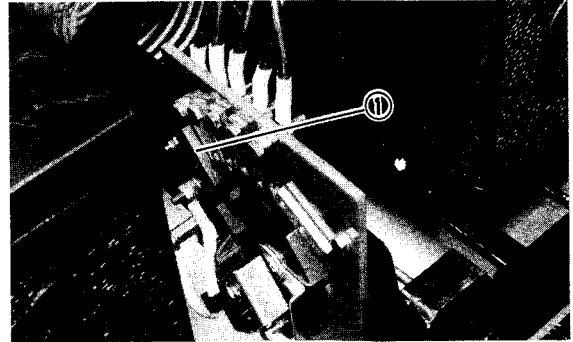

1. Moving arm

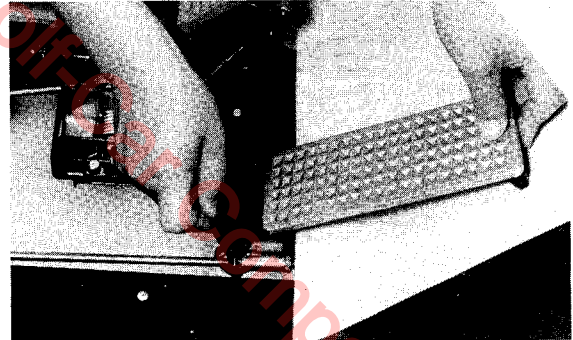

b. How to install speed controller cover.

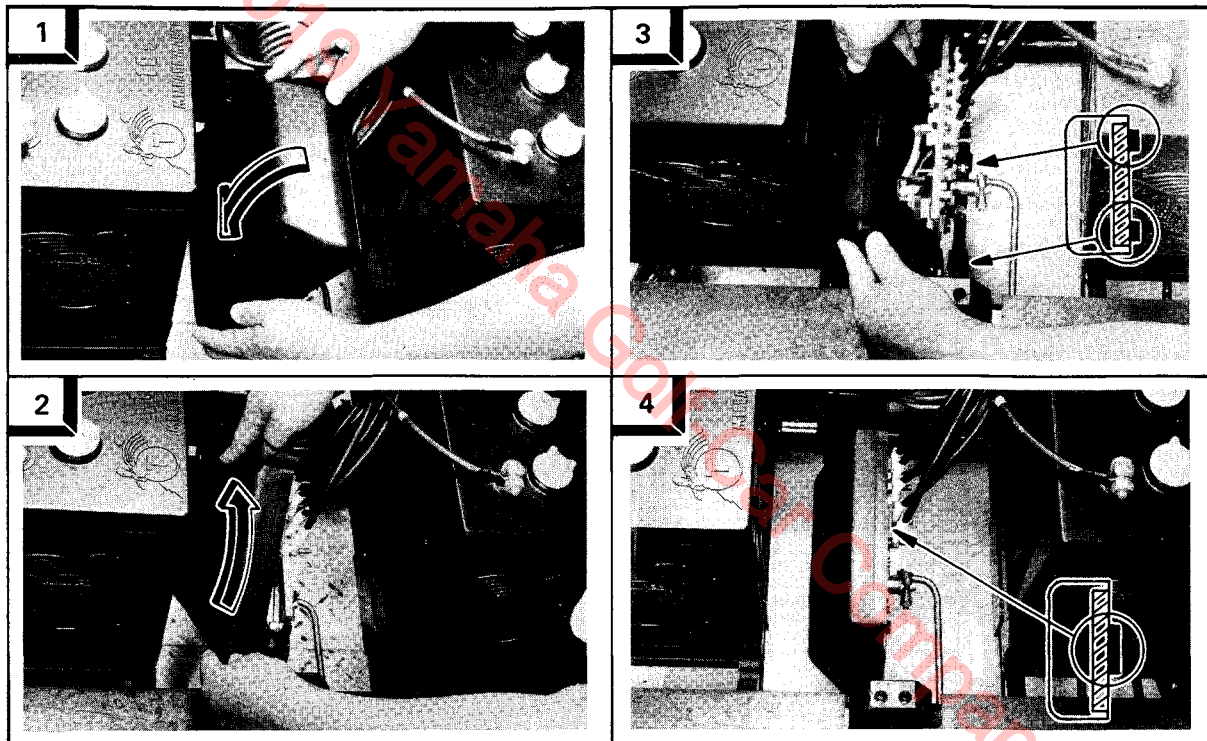

- 5) **Gear box oil**
Remove the rear cowl.

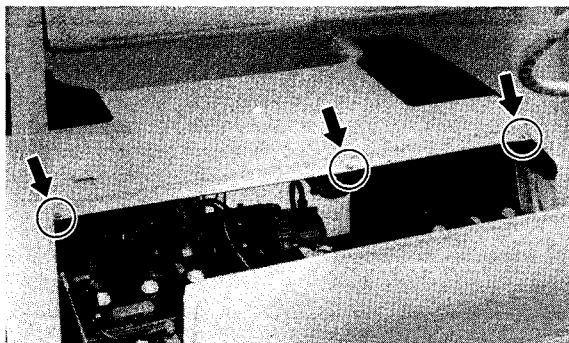

Check the oil level using the level plug.
Add oil if necessary.
Drain the gear box and refill it at least
once every 2 years.

Recommended oil: SAE 90 gear oil
Capacity: 800 cm³ (0.70 Imp qt,
0.85 US qt)

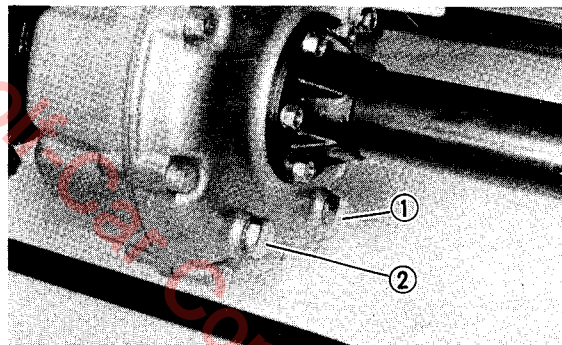

1. Drain bolt
2. Oil level plug



6) Fuse replacement

If any fuse is blown, turn off the ignition switch and the switch in the circuit in question and install a new fuse of proper amperage.

Then turn on the switches, if the fuse immediately blows again, consult a Yamaha dealer or other qualified mechanic.

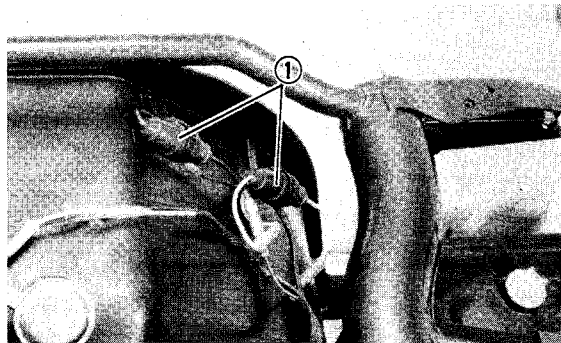

1. Fuse

WARNING:

Never use a fuse with a rating other than specified, or other material in place of a fuse. An improper fuse may cause damage to the electrical system and possible cause a fire, or the lighting and/or ignition may cease to function.

CAUTION:

Don't forget to turn off the main switch when checking or replacing the fuse. Otherwise, it may cause accidental shortcircuiting.

10. STORAGE AND RETURN TO SERVICE

When a golf car is to be stored during the off-season, certain steps must be taken to prevent deterioration and extend the life of the car. Likewise, preparations must be made to return a car to service after storage.

STORAGE PREPARATION

1. Add distilled water to the battery cells to achieve the proper level.
2. Fully charge the batteries.
3. Check the specific gravity of the batteries every eight weeks, and charge them as necessary to maintain the proper specific gravity.
4. Store the batteries in an unheated area during the off-season.
5. Increase the tire pressure to 1.4 kg/cm² (20 psi).
6. Protect the tires from moisture, oil, and ozone.
7. Clean and dry the chassis.
8. Avoid storing the car in damp, humid areas to prevent rust and corrosion.

RETURN TO SERVICE

1. Ensure that the battery is at the proper specific gravity and fluid level.
2. Adjust the tire pressure to 0.9 kg/cm² (13 psi).
3. With the key turned off, check the operation of the brakes, parking brake, accelerator, and steering mechanism.

11. MAINTENANCE CHECK LIST

1) Daily maintenance check list

CODE	PROBLEM
1.	TIRES: <ul style="list-style-type: none">● Inflation● Uneven wear● Damage or cuts
2.	BRAKES: <ul style="list-style-type: none">● Pedal adjustment● Parking lock● Free movement
3.	STEERING: <ul style="list-style-type: none">● Free movement● Full-lock check● Wheel play

CODE	PROBLEM
4.	ACCELERATOR: <ul style="list-style-type: none">● Free movement
5.	RUNNING: <ul style="list-style-type: none">● Forward check● Forward brakes● Reverse check● Back-up buzzer
6.	RATTLES OR UNUSUAL NOISES
7.	BATTERY FLUID LEVEL
8.	CLEANUP

Record the date and, if necessary, the problem code:

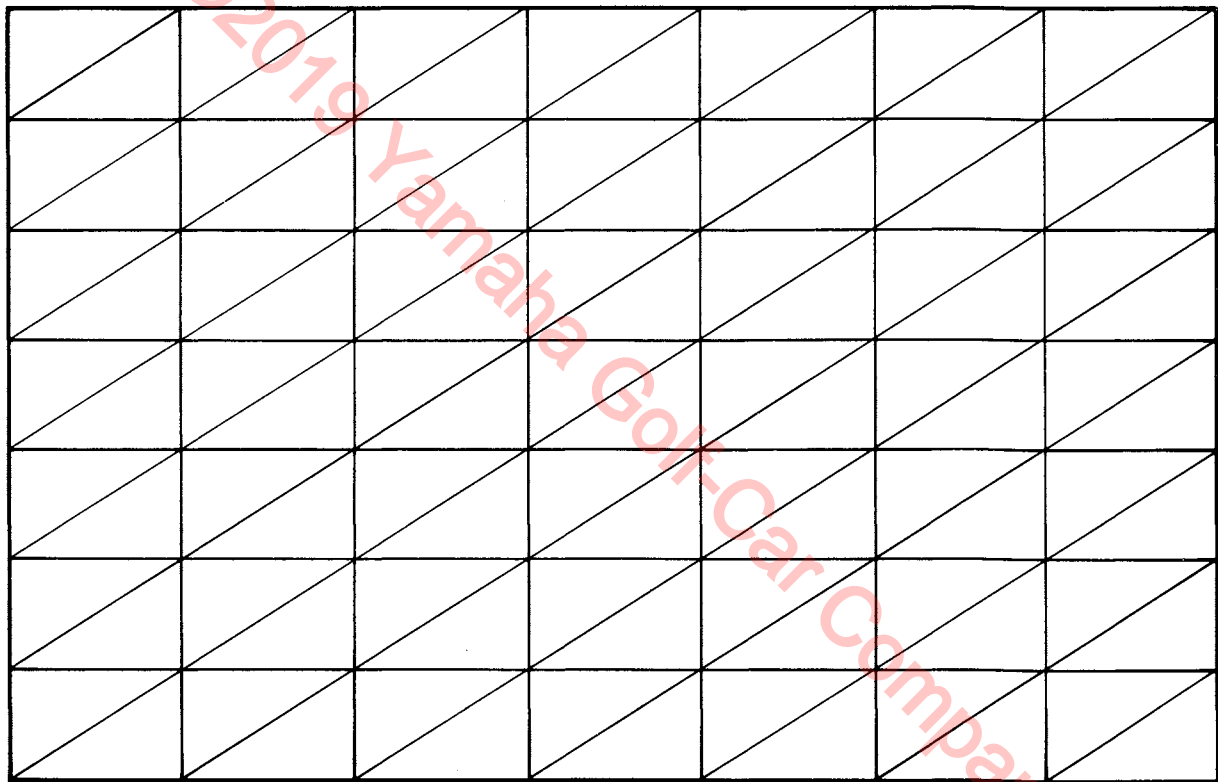

DAILY CHECK (Procedure)

NOTE: _____
Before checking, turn the main switch to the OFF position.

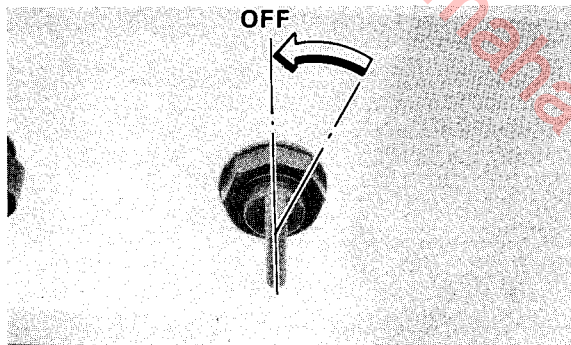

a. Check the steering mechanism free play.

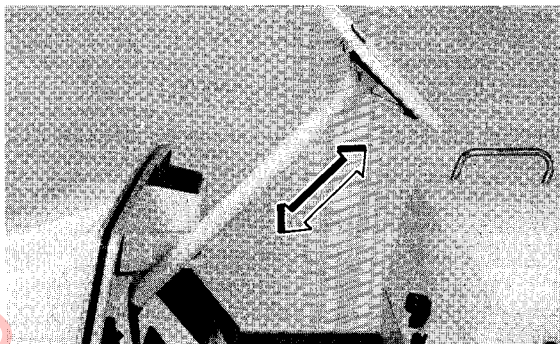

b. Check the steering mechanism movement.

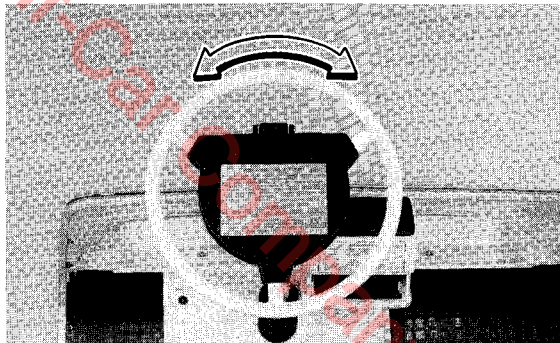

c. Check brake pedal movement.

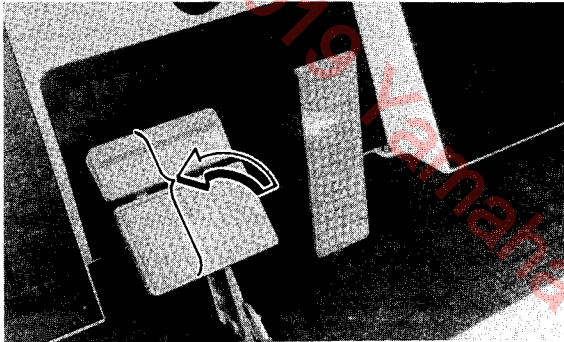

e. Check accelerator pedal operation.

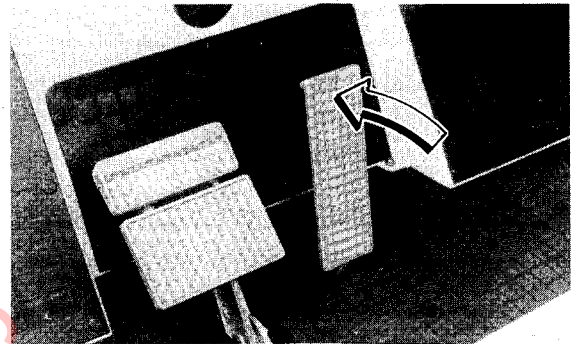

d. Check parking brake operation.

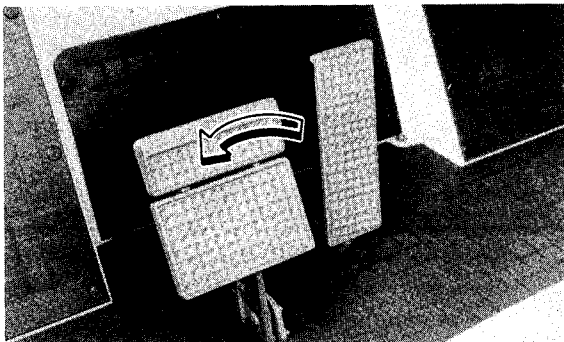

f. Check the back-up buzzer beep at the "REVERSE" key position.

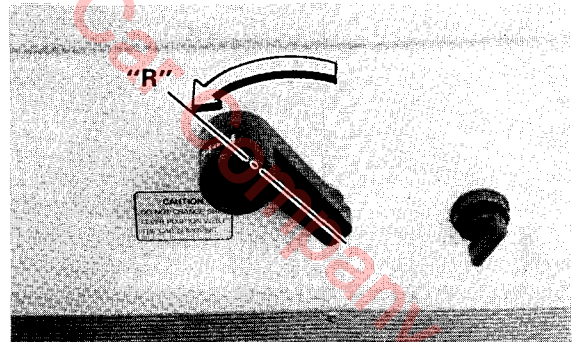

g. Check the tires for cuts or low air pressure.

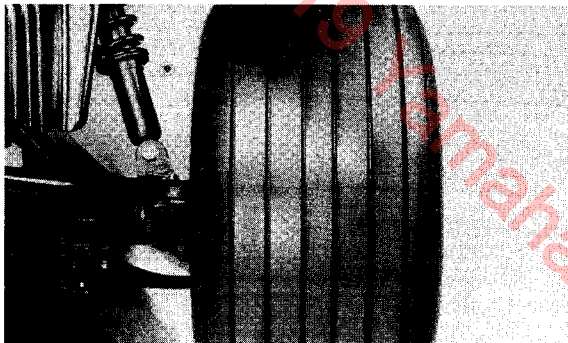

Open the seat for the following checks.
h. Check the fluid level of one of the batteries.

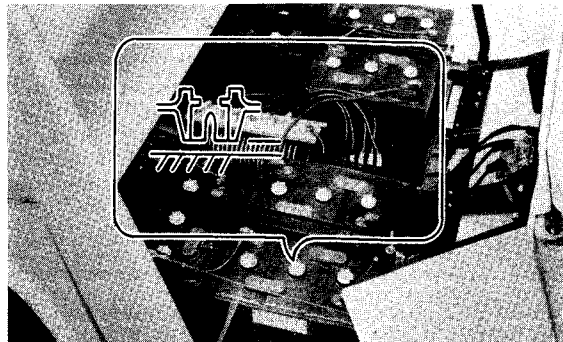

i. Clean the seats and cowl if they're dirty.



j. Check the feel of the car while driving to the line.

2) Monthly maintenance check list

1. Check and adjust the tire pressure.
2. Check for any tire damage.
3. Adjust the brake pedal play.
4. Check the operation of all the cables, and lubricate them.
5. Adjust the parking brake.
6. Check the battery connections and fluid level.
7. Clean the battery and its connections.
8. Check for any loose wires or connections.
9. Wash the car, and wax it if necessary.
10. Check the electrolyte specific gravity.

Record the date, and initial when all the above operations are completed.

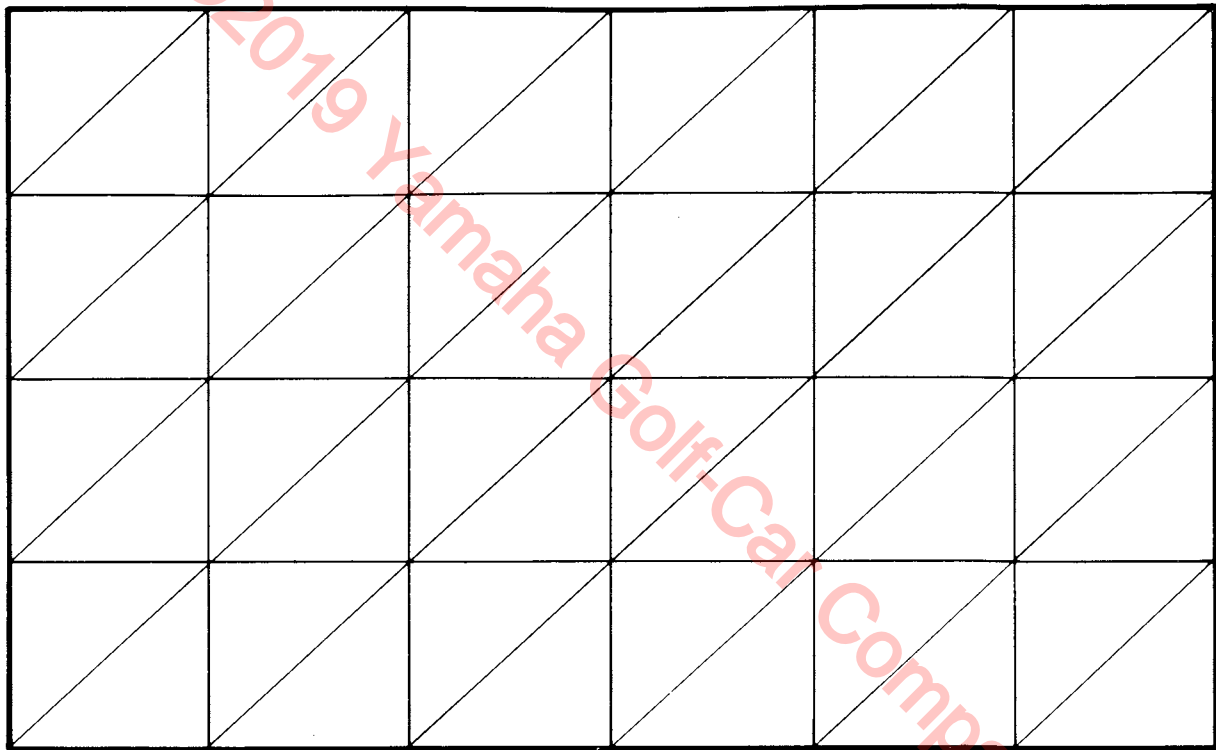

3) Six months and yearly maintenance check list

SIX MONTHS

1. Check accelerator controller contacts.
2. Check solenoid contacts.
3. Check all wire insulation for crack and/or worn spots.
4. Check differential gear box oil level and leakage.
5. Check for wear or damage parking brake ratchet and stopper.
6. Check brake shoe lining thickness.
7. Wax the car.

YEARLY

One year

1. Lubricate all the cables.
2. Tighten all the bolts, nuts, and screws.
3. Adjust the steering gear.
4. Adjust the steering alignment.
5. Check the moving arm and contacts.
6. Adjust the contact allowance.
7. Adjust the brake pedal end play.
8. Check tire groove depth and wheel bearings.
9. Check shock absorber for oil leakage.

Two years

1. Replace differential gear oil.

Four years

1. Check brush and commutator.
2. Check gear box for grease leakage.

Record the date in a box, and initial the adjacent area when the service is completed. Keep this sheet as a permanent record.

1		2		3		4	
6 MONTHS DATE:	YEARLY DATE:	6 MONTHS DATE:	YEARLY DATE:	6 MONTHS DATE:	YEARLY DATE:	6 MONTHS DATE:	YEARLY DATE:
INITIALS	INITIALS	INITIALS	INITIALS	INITIALS	INITIALS	INITIALS	INITIALS

12. SPECIFICATION

ITEMS	DESCRIPTION
Motor	36 volt, DC series wound.
Drive/Transmission	Double reduction helical gear 13.55 : 1, Direct drive motor/axle
Electric system	Six, 6 volts storage batteries (36 volt)
Overall length	91.8 in (2,332 mm)
Overall width	43.9 in (1,116 mm)
Overall height	46.3 in (1,175 mm)
Wheelbase	61.0 in (1,550 mm)
Height of floor	11.2 in (285 mm)
Height of seat from floor	16.5 in (420 mm)
Brakes	Mechanical brake linkage to individual drum brakes on each rear wheel with self-adjusting brake shoe. Parking brake with automatic release.
Front suspension	Independent front wheel suspension. Coil springs with hydraulic shock absorbers.
Rear suspension	Coil springs with hydraulic shock absorbers.
Body	Front cowl; Polypropylene Rear cowl; Polypropylene
Frame	Ladder type pipe structure
Tire type	18 x 8.50 – 8.00 Tubeless – 4 ply rating
Tire pressure	0.9 kg/cm ² (13 psi)
Turning radius	114 in (2.9 m)
Maximum speed	12 mph (19.3 km/h)

13. CIRCUIT DIAGRAM

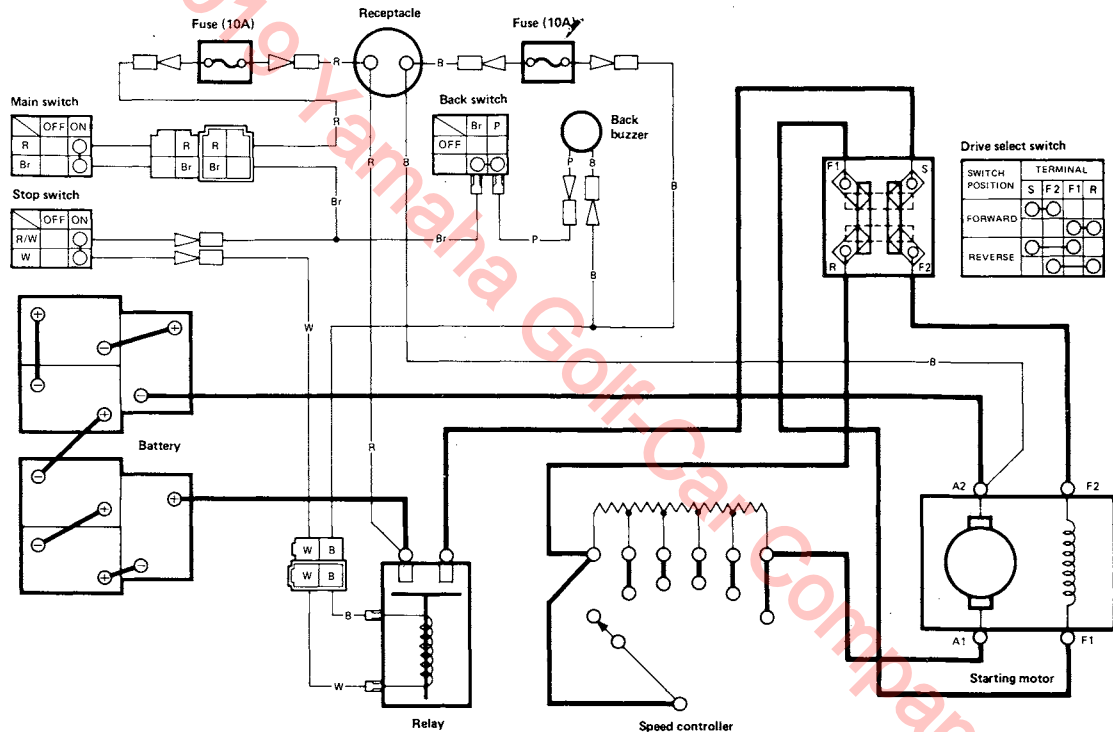

14. WARRANTY INFORMATION

Please refer to your copy of the YAMAHA LIMITED WARRANTY* for details of the warranty offered on your new Yamaha.

The YAMAHA LIMITED WARRANTY* contains the warranty policy, an explanation of the warranty, and other important information. Becoming familiar with these policies will help you make the best use of Yamaha's warranty programs.

There are certain requirements which you must meet in order to qualify for warranty coverage. **FIRST**, your new Yamaha must be operated and maintained properly, as explained in this manual. If you have any questions about procedure in this manual, please consult a dealer. **ABUSE AND NEGLECTED MAINTENANCE MAY LEAD TO MECHANICAL FAILURES WHICH CANNOT BE COVERED UNDER WARRANTY.**

SECOND, IF ANY PROBLEMS OCCUR WHICH YOU FEEL SHOULD BE COVERED UNDER WARRANTY, NOTIFY YOUR DEALER IMMEDIATELY. Don't delay, as small problems left unrepaired can become large problems which may not be covered under warranty.

We recommend that the YAMAHA LIMITED WARRANTY* be used as a folder in which you may keep your registration and other important documents related to your new Yamaha.

* The YAMAHA LIMITED WARRANTY* is to be supplied by a Yamaha dealer at the time of purchase. If you did not receive one, or have lost yours, you may obtain extra copies upon request from your Yamaha dealer or by writing to:

YAMAHA MOTOR CORPORATION U.S.A.

6555 Katella Avenue

P.O. Box 6555

Cypress, California 90630

Attn: Warranty Department

— MEMO —

.....

.....

.....

.....

.....

.....

.....

.....

.....

.....

.....

©2019 Yamaha Golf-Car Company

— MEMO —

©2019 Yamaha Golf-Car Company

— MEMO —

©2019 Yamaha Golf-Car Company

— MEMO —

©2019 Yamaha Golf-Car Company

— MEMO —

©2019 Yamaha Golf-Car Company

— MEMO —

©2019 Yamaha Golf-Car Company

©2019 Yamaha Golf-Car Company

©2010

YAMAHA
GENUINE
Parts & Accessories

01/10/01
1PC - G2E O/M

LIT116260656



Yamaha Motor Corp., USA
Cypress, California

made in

YAMAHA

YAMAHA MOTOR
MANUFACTURING CORP.
OF AMERICA

Printed in U.S.A.
KCC

California-Car Company